

Trimming

Universal Milling Trimmer FS 930

- all different kinds of fill materials possible
- specially suited for trimming extremely high density brushes
- outstanding service life time for wire and abrasive filaments
- for mounting on the tool post of a trimming bench or lathe
- quick set-up and easy adjustment



• HSS tool steel trimmer head

- for synthetics, natural fibres and fine, soft wire

• HM carbide trimmer head with fixed inserts

- for carbon and stainless steel wire, synthetics and natural fibres
- for wire diameters greater than 0.004 inch (0.1 mm)
- grinding jig optionally available for fitting on a standard surface grinding machine

• HM carbide trimmer head with indexible inserts

- for carbon and stainless steel wire diameters greater than 0.008 inch (0.2 mm)
- 5-bladed (each blade turnable and individually replaceable)

• PCD diamond trimmer head

- specially suited for trimming synthetics with abrasive material (e.g. Tynex A)
- 4-bladed (individually replaceable)



Miniature Milling Trimmer MFS 930

- compact design with very small trimming head
- specially designed for trimming small brushes, such as:
 - twist-in brushes
 - dental and junior cup brushes
 - small wheel and cup brushes
- high speed cutting possible, e.g. up to 20,000 rpm for cotton

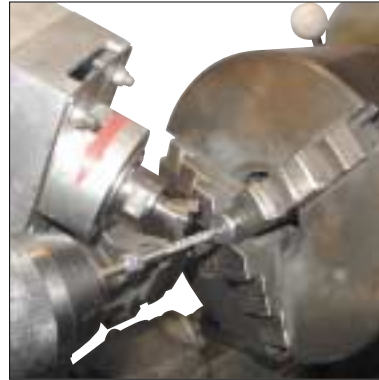

• HSS tool steel trimmer head

- for synthetics, natural fibres and fine, soft wire

• HM carbide trimmer with fixed inserts

- for carbon and stainless steel wire

• PCD diamond trimmer head

- for synthetics with abrasive material (e.g. Tynex A)

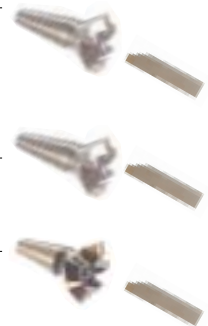

Milling Trimmer WFS 87

- specially designed for trimming wheel, roll and disc brushes
- for natural fibres and synthetics (non-abrasive)
- allows contour trimming (concave, convex)
- wide-faced counter blade of 1 inch (25 mm)

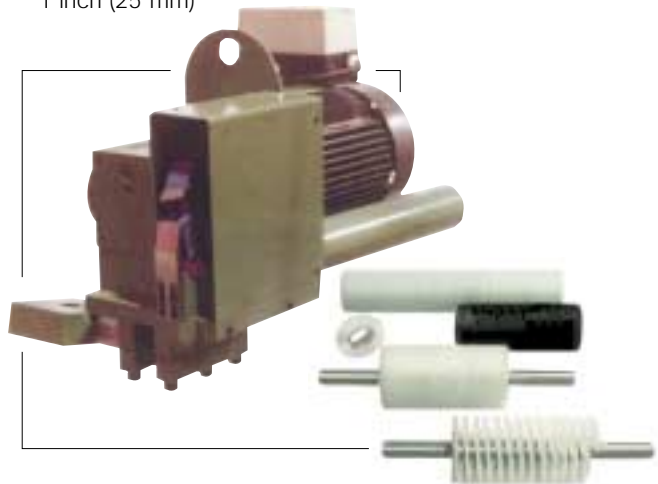

Roller Cutter GR 90

- for wire cutting
- especially for crimped wire hanks
- manual wire feeding and clamping unit MFF 320, optional



Heavy-duty Roller Cutter RS 83 EB

- for twist-knot and brush segment wire cutting
- single station, including one tooling set
- carbide roller cutter blades for outstanding service life time
- blades are easily re-sharpened by flat grinding



Roller Cutter RSR 86

- with 3-station turntable for high capacity cutting operation
- integration into fully automatic production lines possible
- segment size 3 to 8 inch (75 - 400 mm)

Double Heavy-duty Roller Cutter RS 83 DB

- for twist-knot and brush segment wire cutting
- double station for straight cutting, including one tooling set
- quick one-step trimming without turning the brush
- carbide roller cutter blades for outstanding service life time
- blades are easily re-sharpened by flat grinding

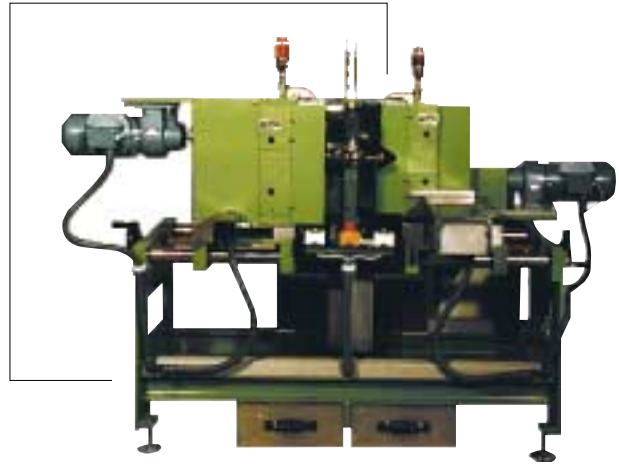

Small Roller Cutter RKR 90

- specially designed for small segment wire cutting
- with turntable for integration into fully automatic production lines
- recommended installation in-line with a Mini segment machine MSM 89

Trimming, Cutting & Finishing

- DFS 90, Double milling trimmer, for strip brushes
- MSA 4, 4-bladed star profile cutter, for strip brushes
- MTB 930, Trimming bench, for roll and wheel brushes
- PBS 90, Cup brush cutting machine
- SPR 86, Segment press and roller cutter
- HC 84, Simple hank cutter
- AGB 906, Automatic assembly and trimming device for twist-knot, cup and wheel brushes
- BST, Brush trimming by punching
- FBA 10, High capacity paintbrush trimming and flagging line
- FLA 10, Paintbrush flagging device
- DSA 92 / DSA 971, Wire cutting and placing device for strip brush machines
- FVD 92, Automatic dental and jewellery brush trimming

Servo Stock Cutter AS 940S

- sophisticated design for high speed cutting of synthetic bundles, at a speed of up to 70 cuts/min., e.g. for toothbrush production
- individually adjustable clean-cut length which is independent of the actual bundle cutting length
- extra high cutting accuracy of +/- 0.4 mm (+/- 0.016 inch)



- cut lengths down to 10 mm (0.4 inch), optionally available
- outstanding blade service life time, e.g. up to 6,000 cuts on abrasive 45 mils-1.02 mm (0.04 inch)-240 grit
- different, optimised blade types available



Automatic Stock Cutter AS 940

- capacity of up to 35 cuts/min.
- clean cut length is same as actual bundle cutting length
- cutting accuracy of +/- 1.0 mm (+/- 0.04 inch)
- cut lengths down to 22 mm (0.87 inch)
- outstanding blade service life time, e.g. up to 6,000 cuts on abrasive 45 mils-1.02 mm (0.04 inch)-240 grit
- different, optimised blade types available

Semi-automatic Stock Cutter AS 941

- utilises advanced cutting system with a low-cost design for industrial applications
- capacity of up to 35 cuts/min.
- manual hank loading, without magazine
- clean cut length is same as actual bundle cutting length
- cutting accuracy of +/- 1.0 mm (+/- 0.04 inch)
- cut lengths down to 22 mm (0.87 inch)
- outstanding blade service life time, e.g. up to 6,000 cuts on abrasive 45 mils-1.02 mm (0.04 inch)-240 grit
- different, optimised blade types available

Automatic Double Stock Cutter ASD 940

- universal unit, based on the proven standard design of the AS 940
- high flexibility in changing material through 2 cutting stations
- no blade changing required, as optimised blades are already installed for both abrasives and standard synthetics

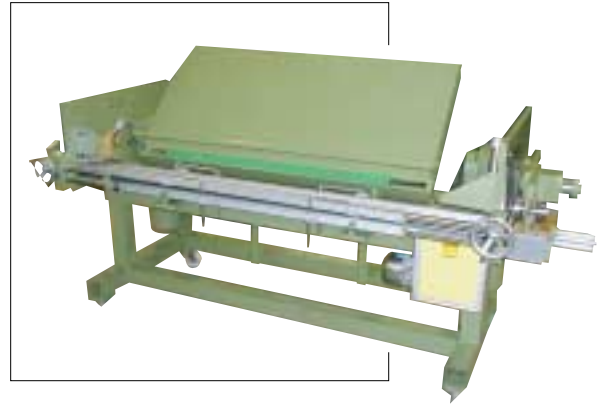

Wire Crimping, Flattening and Cutting

- SWC 950, Automatic single wire cutting and sorting line
- W 77, Wire crimping line
- STW 87, Wire crimping and hank production line
- DA 74SP, Wire crimping and cutting line for greater wire diameters
- DA 74, Cutting and stapling device
- FWR 250, Flat wire rolling and cutting line
- S65 Manual wire saw for straight oil-tempered wire 0,006-0,031 inch (0,15-0,8 mm)

Clipper Trimmer ZS 960

- for fine hair and synthetics
- including hydraulic pressure gauge for reproducible adjustment
- including tiltable head adjustment
- exchangeable head for Baer ZMU trimmer
- exchangeable trimmer blade for Baer ZMU trimmer



HSS tool steel clipper trimmer blades

- 5 inch (125 mm) wide
- available no. of teeth: 26, 32, 40, 50

HM carbide clipper trimmer blades

- 5 inch (125 mm) wide
- available no. of teeth: 26, 32, 40, 50

Clipper Trimmer ZS 90

- universal wire brush trimming, including automatic blade lubrication
- flexible adjustment for cutting all kinds of brushes
- for installation on a trimming bench

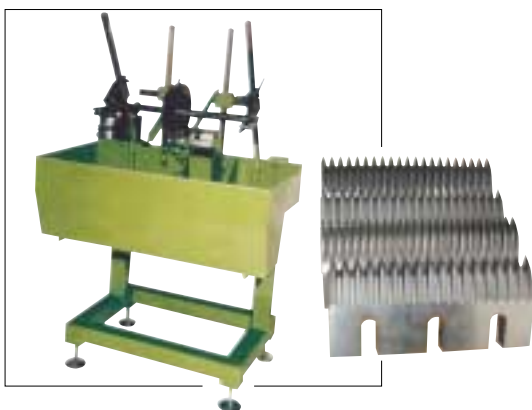

• Base frame for clipper trimmer ZS 90

- with optional tooling for cutting of all kinds of brushes
- including waste trough

HSS tool steel clipper trimmer blades

- 6.5 inch (166 mm) wide
- available no. of teeth: 17, 19, 20, 21, 27, 39, 50

Brush Trimming Machine FVT-W

- for wheel brush trimming, only
- trimming of large brush segments with short fill (e.g. twist-knot)
- optionally available with grinding station for wheel brushes (e.g. hard twist-knot brushes)

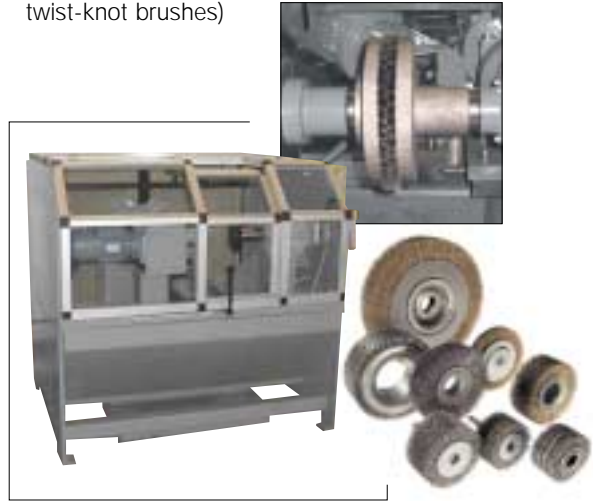

Universal Trimming Machine FVT-S

- universal device for all kinds of:
- disc brushes, wheel brushes, cup brushes, tapered and medium size staple set brushes, end brushes, mini segment brushes
- for synthetics, abrasive nylon and wire



Wheel Brush Trimming Machine FVT 1000

- 2 stations, high capacity trimming
- for integration into fully automatic production lines



- for synthetics, abrasive nylon and wire
- including one tooling set for brush clamping

Surface Trimming Machine FTU 16

- for surface trimming of flat, long staple set brushes
- optionally for disc brushes

Trimming Benches for Cylinder Brush Trimming

- MTB 930, up to 40 inch (1,000 mm)
- MTB 500, up to 200 inch (5,000 mm)
- TBT 90, heavy-duty cylinder brushes up to 248 inch (6,300 mm)

The world's leader in
production systems for...

- **Paint Brushes**
- **Artist's Brushes**
- **Strip & Roll Brushes**
- **Twist-Knot Brushes**
- **Brush & Mini Segments**
- **Dental & Polishing Brushes**
- **End Brushes**
- **Street Sweeper Brushes**
- **Twisted-In Brushes**

- **Bundle Production**
- **Toolings**
- **Wire Cutting Equipment**
- **Wire Crimping and Flattening
Equipment**
- **Specialty Machines**

WÖHLER

Wöhler Technische Bürsten Maschinenbau GmbH
Schützenstraße 38
D-33181 Bad Wünnenberg
Telefon: + 49 2953 73-29
Telefax: + 49 2953 73-34
mb@woehler.de
www.woehler.com

www.woehler.com

WÖHLER



**Cutting and Trimming
Special**

